

Volume flow measuring system

Measuring system to measure flow rate in dry emissions with a probe using the differential pressure principle.

Features

- Measurement of emission speed
- Calculation of volume flow at standard conditions with the evaluation unit D-FL 100-10 (optional)
- Adjustable parameters
- Automatic back purging device (optional)
- Versions with or without counter-support and for point measurement.

Applications

- Volume flow measurement at high temperatures
- Plants with large or small flue cross-sections
- Volume flow measurement at high pressure.

Approvals

- Suitability-tested by the TÜV Hamburg, test report 128CU11650
- Itemized in the list of suitable measuring devices for continuous emission measuring.
- MCERTS.

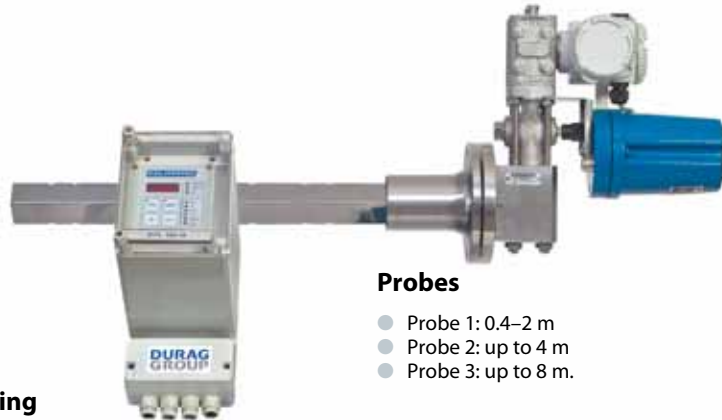

Probes

- Probe 1: 0.4–2 m
- Probe 2: up to 4 m
- Probe 3: up to 8 m.

System components

- Mounting flange
- Flow probe
- Counter-support
- Differential pressure transducer
- Cross-over cock
- Probe adapter.

Options

- Microprocessor evaluation unit **D-FL100-10**
- Absolute pressure transducer
- Temperature transducer
- Weather protection covers
- Automatically controlled back purging device
- Special designs in other materials for applications with particularly aggressive exhaust gases or high gas temperatures
- dP-transducer in Ex-version.

Measuring principle

The D-FL 100 measuring system operates according to the differential pressure principle. The probe has two separate chambers, between which the flow builds up a differential pressure. Taking account of the other flow parameters such as, e.g. absolute pressure and temperature, the volume flow can be converted from operating to standard conditions with the help of the D-FL 100-10 microprocessor evaluation unit.

Models

- **D-FL 100 probe assembly** with assembly of measuring transducer on the probe (not for probe 3)
- **D-FL 100 hose assembly** with the measuring transducer connection via hose line.

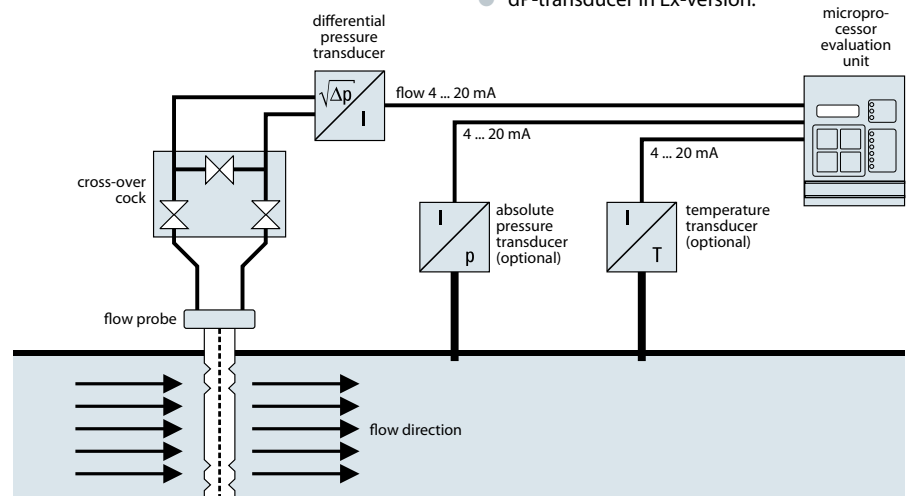

measurements	flue gas velocity, volume flow ¹⁾	accuracy	<2% of measuring range
measuring ranges	0–3000000 m ³ /h / 3–40 m/s	detection limit	<3 m/s
measuring principle	differential pressure	reference point drift	<0.5% of measuring range/month
flue gas temperature	above dew point up to 400 °C, optional up to 800 °C	zero point drift	<0.5% of measuring range
flue gas pressure	-700 up to 1000 hPa, optional higher	supply voltage	14–45 VDC 115 / 230 VAC, 50 / 60 Hz, 50 VA ²⁾
duct diameter	0.4–8 m	dimensions (h x w x d)	probe: 380 x 160 x (300 + probe length) mm
ambient temperature	-20 up to +50 °C	weight	32 kg + 6.8 kg/m probe length
protection	IP65, Ex optional	purge air supply	6–8 bar for back purging if necessary
measuring outputs	0 / 4–20 mA / 500 Ohm ²⁾	remarks	¹⁾ optional pressure and temperature correction
digital outputs	3 relay outputs, permissible load 250 V, 100 VA ²⁾		²⁾ only with evaluation unit